

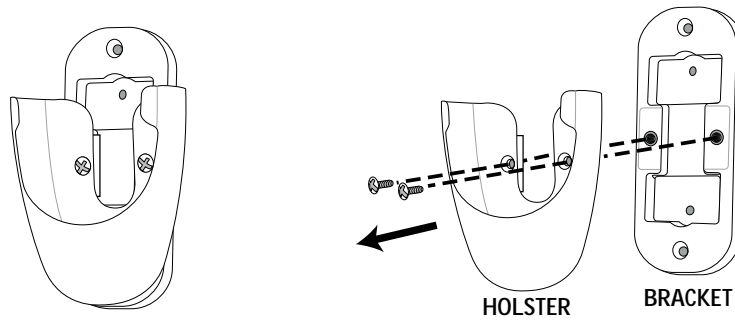

ADVAN•TOUCH ♦ W-62 BRACKET/HOLSTER REMOVAL

Step 1. Remove the two 6-32 x 5/16" screws holding the bracket to the holster. Save screws for later.



ADVAN•TOUCH ♦ CONTROL BRACKET INSTALLATION

CAUTION! Do not use with wall dimmer.

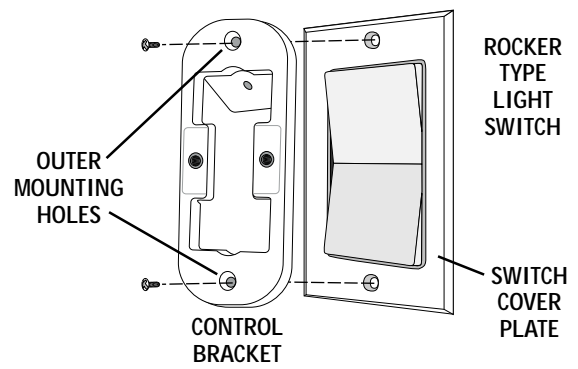
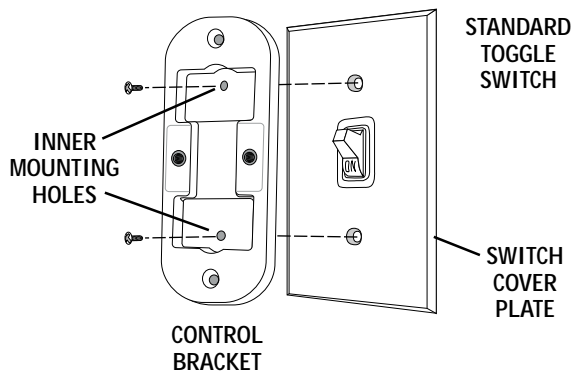

Standard Light Switch

Step A. Remove the two screws holding the switch cover plate. Do not remove the cover plate.
Step B. Orient the control bracket as shown and line up the two inner mounting holes with those on the switch.
Step C. Install and tighten screws by *hand* only.

Rocker Light Switch

Step A. Break off the two tabs by pushing outward.
Step B. Remove the two screws holding the switch cover plate. Do not remove the cover plate.
Step C. Orient the control bracket as shown and line up the two inner mounting holes with those on the switch.
Step D. Install and tighten screws by *hand* only.

Wall Installation

Step A. Locate a 2x4 wall stud in a convenient location.
Step B. Orient the control bracket as shown over the 2x4 stud.
Step C. Use the 1" wood screws in either the inner or outer mounting holes. Install and tighten screws by *hand* only.

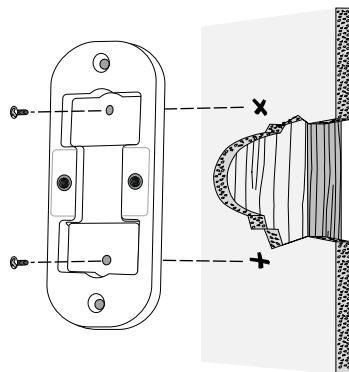

Note: The wall anchors and 6-32 x 1" screws may be used in situations where mounting to a stud is not possible. Use the inner mounting holes. After securing the anchor, discard the anchor's pointed screws and use the 6-32 decor ovalhead screws supplied.

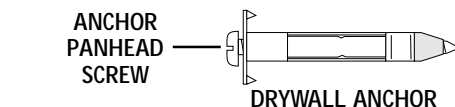

ADVAN•TOUCH ♦ ATTACH HOLSTER TO BRACKET

Step 2

After you have completed installing the bracket to the wall, using the 2 screws removed in Step 1, attach the W-62 holster to the bracket.



ADVAN•TOUCH ♦ BATTERY INSTALLATION

Open Battery Door by pressing down on the insert tab provided.

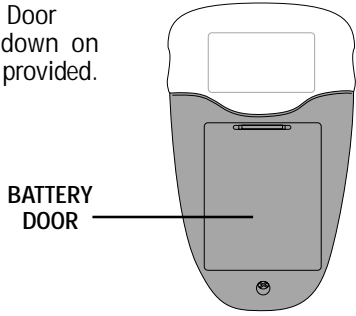

Install 4 "AAA" alkaline batteries in the space provided. Please observe proper polarity placement. Replace Battery Door.

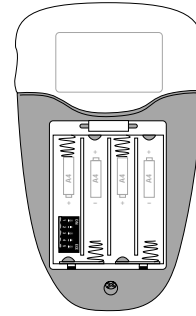

ADVAN•TOUCH IMPORTANT OPERATING NOTES

Power turned off, interrupted or failure:

The remote control is battery operated, therefore if the power is turned off, interrupted or you experience a power failure, the remote control remembers the previous setting for both fan and light.

Button operation:

Rapid button operation causes erratic fan operation.

For reliable operation of the remote control and fan you must wait one second between button presses to allow the radio signal to be transmitted to the fan and received.

ADVAN•TOUCH OPERATION

Fan Operation

The Advan•Touch fan is controlled by the remote control. The fan button located in the center top row, turns the fan on or off.

With the fan on, the control display will indicate an up or down moving arrow that shows direction and places a box around the operating speed. It will also show you a moving fan image that tells you the fan is on and what direction the blades are moving in (looking up from underneath the fan).

Just below the fan button, there are two ▲ and ▼ buttons. Use the ▲ button (on the left) to increase fan speed once for each press and the ▼ button (on the right) to decrease speed once for each press.

Use the reverse button to change the direction of the rotation. Reverse operates at any speed. The fan returns to its set speed after reversing. You will see the airflow direction arrow change each time to press reverse.

Light Operation

The light is turned on or off independently of the fan by pressing the LIGHT button. Keep pressing the button (hold it down) and it becomes a dimmer. The light varies from "bright" to "dim" over approximately 8 seconds. This sequence will reverse the light when it reaches the brightest or dimmest level if you continue to hold the LIGHT button. Release the button when the desired level is reached.

Safe Exit Feature

To turn off the light, hit the button once and the light will increase slightly if less than 100% and gradually turn off, taking approximately 20 seconds. (If set at 100%, light will decrease to about 50% and then gradually turn off.) This enables you to leave a room or your home safely before the lights go completely out.

Push the light button two times and the light will immediately dim to about half and then turn off completely.

The fan will remember the last light setting and will come on at that setting until changed.

Bulb Saver Feature

When the light is turned on, the brightness will take 1.5 seconds until it reaches the present level. This feature helps extend light bulb life.

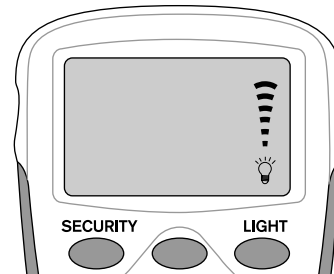
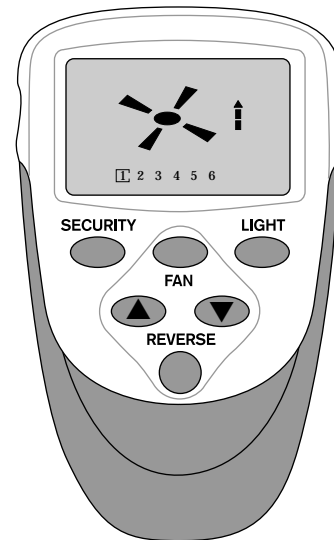



SECURITY FEATURE

Pressing the 'SECURITY' button will start the Security lighting program. The controller beeps and indicates 'SECURITY'. The light will automatically turn ON and OFF in a seemingly random manner over an eight and a quarter hour programmed cycle that is designed to give the home a "lived-in" look. Regardless of the light setting when switching to the Security mode (lights on or off, dim or bright), the lights will increase to high brightness and then begin the Security cycle. This cycle is then repeated continuously until cancelled by pressing the 'SECURITY' button.

At any time during the Security mode you may adjust the fan speed, reverse the direction, operate in Auto Speed or Winter, use Saver or run the Test mode without affecting Security mode.

You may still turn the light ON and OFF (or OFF and ON) manually for temporary lighting, but the light will continue to operate automatically at its programmed times.

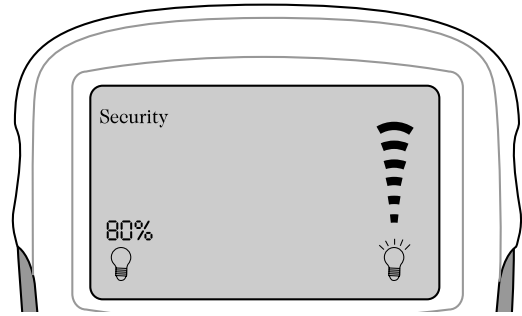

SECURITY MODE CYCLE

- | | |
|------------------------------------|-----------------------------------|
| 1. On for 60 minutes (80% bright) | 4. Off for 60 minutes |
| 2. Off for 30 minutes | 5. On for 90 minutes (50% bright) |
| 3. On for 120 minutes (30% bright) | 6. Off for 60 minutes |

ADVAN•TOUCH ♦ CHANGING FREQUENCY SETTING

Note: All fans leave the factory set to '10000'.

You will have to change the dip switch settings in the remote if you are using more than one fan in the same area and want to control them separately.

Step 1. At the circuit breaker or fusebox, turn the power off for the fan you want to change.

Step 2. Open the battery door of the Advan•Touch control and remove the first battery on the left to gain access to the dip switches.

Step 3. Change the dip switch settings, assuring that they are different from the previously installed Advan•Touch fan(s).

Step 4. Re-install the battery in the proper polarity and the battery door on the control.

Step 5. At the circuit breaker or fuse box, turn the power back on for the fan whose frequency you are changing.

Step 6. Within 20 seconds of restoring power, push the and buttons at the same time. Hold for a few seconds. You will see the LCD Screen flash all of the graphics. You should now have control of the fan.

Note: You may want to label your controls to assure you do not mix them up.

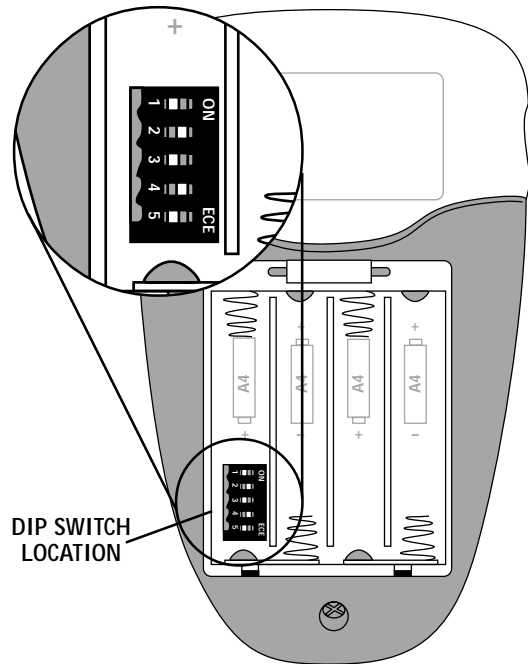

ADVAN•TOUCH ♦ IF THE FAN DOES NOT WORK

If the fan is not functioning after installation:

Step 1. Check to make sure the batteries are installed properly in the control.

Step 2. Turn the power off to the fan (from the circuit breaker) for at least 5 seconds.

Step 3. Turn the power back on (at the circuit breaker) and push the and buttons at the same time, within 20 seconds from restoring power.

Step 4. The fan should now function properly.



TROUBLESHOOTING

Before Requesting Service: Please follow this troubleshooting guide before contacting your dealer for assistance.

Caring for Finishes: For cleaning, a soft brush or lint-free cloth should be used to prevent scratching the finish. A vacuum cleaner brush nozzle can remove heavier dust. Surface smudges or an accumulation of dirt and dust can easily be removed by using a mild detergent and slightly dampened soft cloth. An antistatic agent may be used, but *never* use abrasive cleaning agents. These will damage the finish. Painted and high-gloss blades may be cleaned in the same manner.

Blades: Wood finish blades should be cleaned with a furniture polishing cloth. Occasionally, a light coat of furniture polish may be applied for added protection and beauty.

Never Lubricate this Fan!

The precision motor at the heart of your Casablanca fan features sealed bearings that are lubricated for life. Do not attempt to oil the motor.

Changing Light Bulbs

Be sure to turn power to the fan OFF at the wall switch or circuit breaker before changing light bulbs. Replace bulbs with same type as removed from the fixture. Each fan is rated for a maximum **TOTAL** wattage of lighting.

Exceeding the rated maximum allowable wattage for the fan will burn out the fan electronics module and void the warranty.

PROBLEM	ADVAN•TOUCH	POSSIBLE REMEDIES
FAN WILL NOT START	-Check main circuit fuses, circuit breakers, or wall switch position. Check all wire connections, making sure the power is turned off during this inspection. -Pin connectors are not making good contact. Check all connections. -Battery weak—install fresh battery. -Fan receiver defective—replace.	
FAN DOES NOT RESPOND TO REMOTE CONTROL	-Power to fan is off. -Wrong remote is being used. -Remote dip settings changed—see instructions for changing the frequency setting.	
FAN WOBBLER OR SHAKES EXCESSIVELY	-Be sure canopy pin is properly set into the slot on the ball. -Check that bladeholders have not been bent during installation and blades are balanced. -Hanger bracket and/or ceiling outlet are loosely attached: Make sure that the hanger bracket is tightly attached to the ceiling outlet box. Make sure that the downrod assembly is secured firmly. -Downrod is loosely attached to downrod base: Make sure that all screws are securely tightened.	
FAN NOISY DURING OPERATION	-Check and tighten light fixture retaining screws, glass shade screws and/or the light bulb(s). -Tighten canopy screws and mounting plate assembly. Check that the wire nuts inside the canopy and switch housing are not touching the metal parts or have fallen off the wire splices. Tighten as necessary. -Tighten blade holders to flywheel (or direct drive motor)/and blade to bladeholder screws. -Make sure all screws in the motor housing are snug, but not overly tight. Defective bulb: Replace bulb.	
DOES NOT RUN ON LOW SPEED	-If new, "break-in" may be required - run at higher speed for several days.	
BATTERY LIFE SEEMS SHORT	-Not using Alkaline batteries: Replace with ALKALINE batteries.	

FAN O.K., NO LIGHT: Check for burned out light bulb. Check fan light wires.

LIGHT O.K., NO FAN: Check connectors, may not be making good contact.

REMOTE CONTROL OF FAN IS ERRATIC: Check batteries installed correctly. Install fresh ALKALINE batteries.

FAN STARTS WORKING BY ITSELF: Frequency interference; Change dip switch code.

For questions or to locate the nearest
Casablanca Authorized Service Center
call toll free:

1-888-227-2178

Or visit us on the web at:

www.CasablancaFanCo.com