

Thermal Electric Wine Cellar

Thermique Electrique Rafrâchisseur à Vin

Térmico Eléctrico Enfriador de Vino

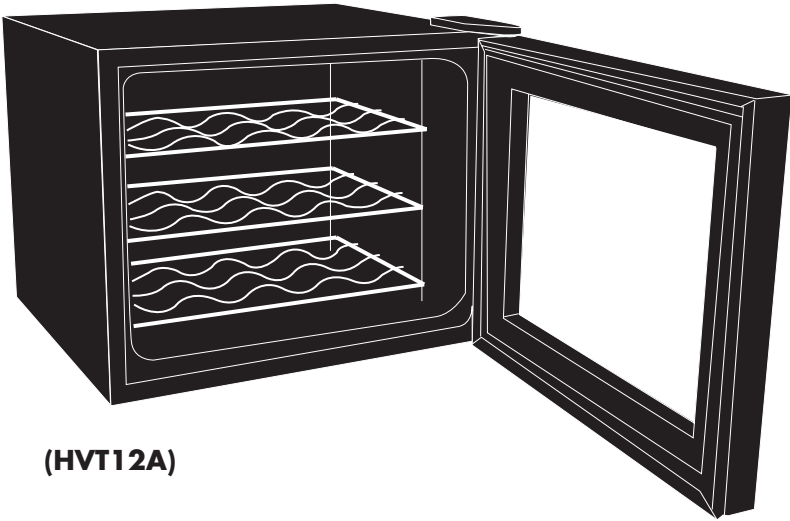

(HVT12A)

User Manual

Model # HVT12A, HVW18

Guide de l'Utilisateur

Modèle # HVT12A, HVW18

Manual del Usuario

Para Modelo de # HVT12A, HVW18

Haier

Quality ⁿ Innovation ⁿ Style

IMPORTANT SAFEGUARDS

When using this appliance, always exercise basic safety precautions, including the following:

- 1) Read all of the instructions before using this appliance.
- 2) This wine cellar must be properly installed in accordance with the installation instructions before it is used. See grounding instructions in the installation section.
- 3) Never unplug your wine cellar by pulling on the power cord. Always grasp the plug firmly and pull straight out from the outlet.
- 4) Repair or replace immediately, all electric service cords that have become frayed or otherwise damaged. Do not use a cord that shows cracks or abrasion damage along its length, the plug or the connector end.
- 5) Unplug your wine cellar before cleaning or before making any repairs.
Note: If for any reason this product requires service, we strongly recommend that a certified technician performs the service.
- 6) If your wine cellar is not being used, we recommend that you remove the door and leave the shelves in place. This will reduce the possibility of danger to children.
- 7) This wine cellar should not be recessed or built-in an enclosed cabinet. It is designed for freestanding installation only.
- 8) Do not operate your wine cellar in the presence of explosive fumes.
- 9) Do not store foods in wine cellar as interior temperature may not be cool enough to prevent spoilage.

SAVE THESE INSTRUCTIONS

DANGER

Risk of child entrapment. Before you throw away your old appliance, take off the doors. Leave the shelves in place so that children may not easily climb inside.

Table Of Contents

	PAGE
IMPORTANT SAFEGUARDS	1
PARTS AND FEATURES	3-4
INSTALLING YOUR WINE CELLAR	5-7
Unpacking your wine cellar	5
Leveling your wine cellar	5
Proper Air Circulation	5
Electrical requirements	5
Use of extension cords	6
Install Limitations	6
Door Alignment	6
Installing Spacer	7
WINE CELLAR FEATURES AND USE	7
Temperature Adjustment	7
PROPER WINE CELLAR CARE AND CLEANING	8
Cleaning and Maintenance	8
Power interruptions	8
Vacation & moving care	8
TROUBLESHOOTING	9
WARRANTY	10

Thank you for using our Haier product. This easy-to-use manual will guide you in getting the best use of your wine cellar.

Remember to record the model and serial number. They are on a label in back of the wine cellar.

Model number

Serial number

Date of purchase

Staple your receipt to your manual.
You will need it to obtain warranty service.

Knowing Your Wine Cellar

Parts and Features

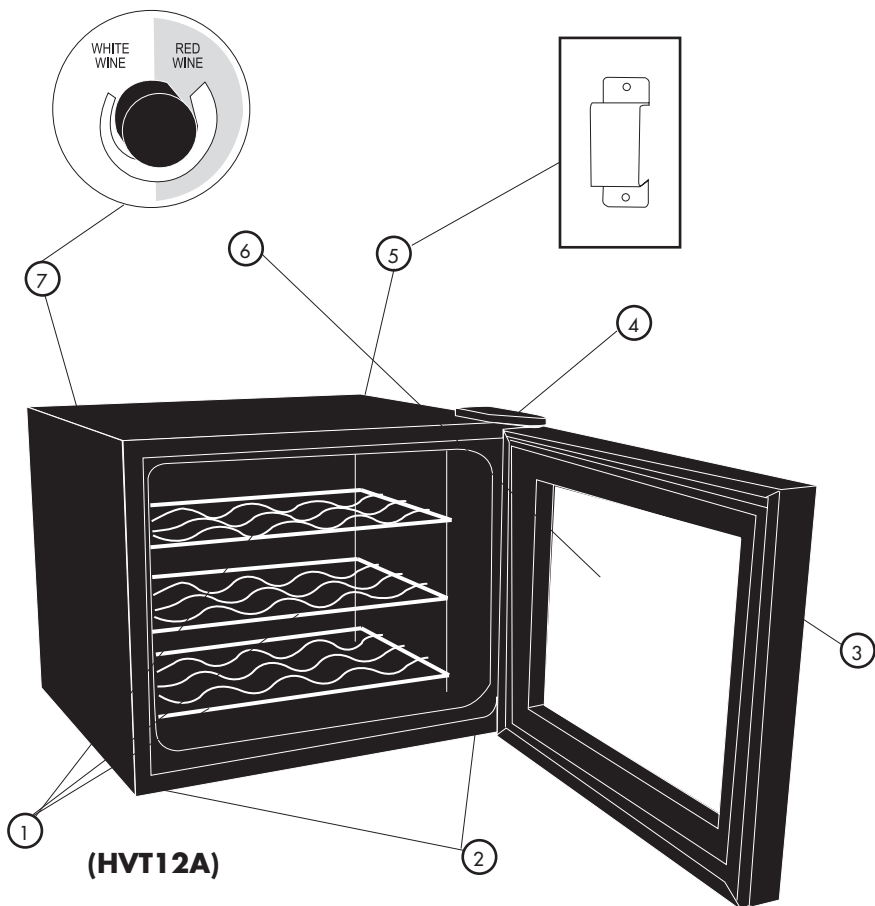

1. Removable Shelves
2. Leveling Legs (4) (not shown)
3. Recessed Handle
4. Hinge Cover

5. Ventilation Spacer
6. Glass See-through Door (door frame will vary per model purchased)
7. Adjustable Temperature Control

Knowing Your Wine Cellar

Parts and Features

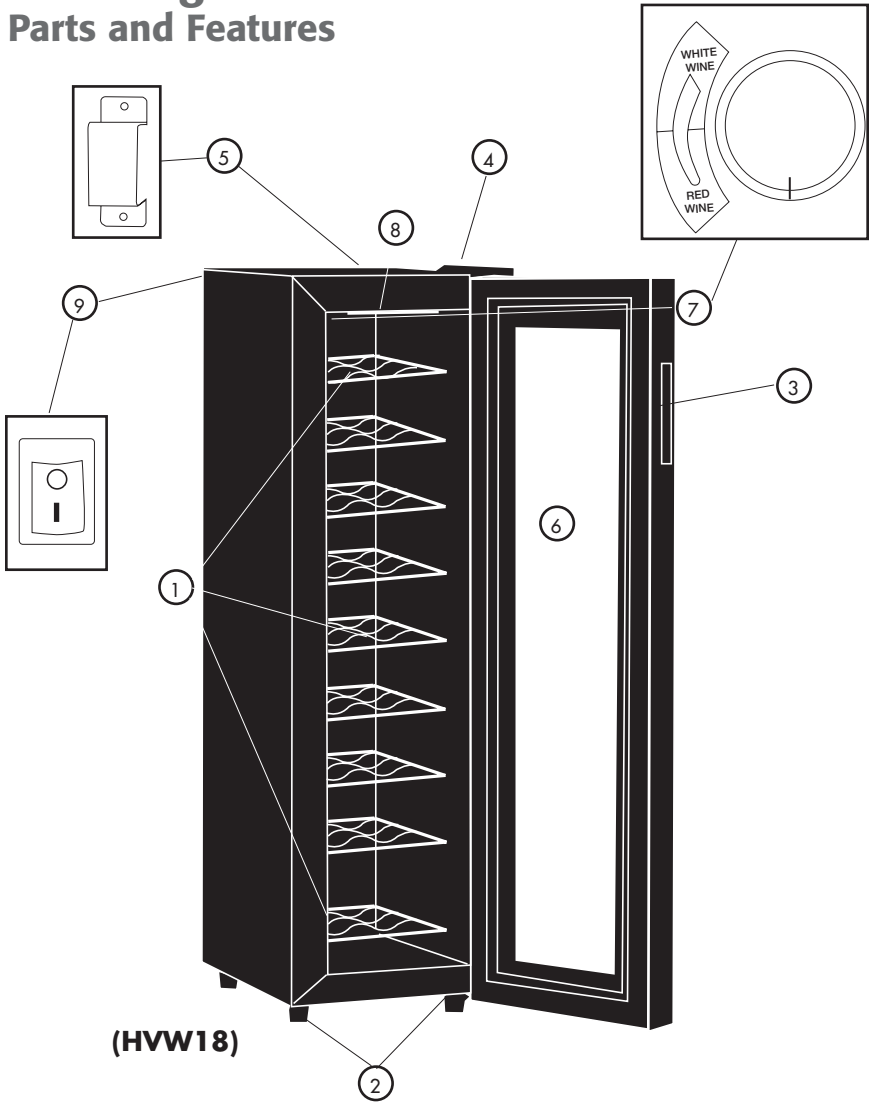

1. Removable Shelves
2. Leveling Legs
3. Recessed Handle
4. Hinge Cover
5. Ventilation Spacer

6. Glass See-through Door (door frame will vary per model purchased)
7. Adjustable Temperature Control
8. Light
9. Light On/Off Switch

Installing Your Wine Cellar

Unpacking your Wine Cellar

1. Remove all packaging material. This includes the base and all adhesive tape holding the wine cellar accessories inside and outside.
2. Inspect and remove any remains of packing, tape or printed materials before powering on the wine cellar.

Leveling your Wine Cellar

- Your wine cellar has 4 leveling legs. After properly placing your wine cellar in its final position, you can level your wine cellar.
- Leveling legs can be adjusted by turning them counterclockwise to raise your wine cellar or by turning them clockwise to lower your wine cellar.
- Install the legs by screwing in the legs into the preset screw holes. (Please note that the leg which stands on the hinge is the shorter leg.)

Proper Air Circulation

- To assure your wine cellar works at the maximum efficiency it was designed for, you should install it in a location where there is proper air circulation and electrical connections.
- The following are recommended clearances around the wine cellar:
 Sides.....2" (50mm)
 Top.....4" (100mm)
 Back.....2" (50mm)
- Do not over fill your wine cellar for proper internal air circulation.

NOTE: Allow enough space in the front of the unit to open the door to 120°.

Electrical Requirement

- Make sure there is a suitable power Outlet (115 volts, 15 amps outlet) with proper grounding to power the wine cellar.
- Avoid the use of three plug adapters or cutting off the third grounding in order to accommodate a two plug outlet. This is a dangerous practice since it provides no effective grounding for the wine cellar and may result in shock hazard.

Use of Extension Cords

- Avoid the use of an extension cord because of potential safety hazards under certain conditions. If it is necessary to use an extension cord, use only a 3-wire extension cord that has a 3-blade grounding plug and a 3-slot outlet that will accept the plug. The marked rating of the extension cord must be equal to or greater than the electrical rating of the appliance.

Install Limitations

- Do not install your wine cellar in any location not properly insulated or heated e.g. garage etc.
- Select a suitable location for the wine cellar on a hard even surface away from direct sunlight or heat source e.g. radiators, baseboard heaters, cooking appliances etc. Any surface unevenness should be corrected with the leveling legs located on the front and rear bottom corners of the wine cellar. Avoid placing unit where there may be electrical interference.
- Your wine cellar is designed for free-standing installation only. It is not designed for built-in application.

NOTE: To minimize the risk of rusting, leakage and insulation damage, avoid placing the unit in a place where heavy moisture is present. Under no circumstances spill or directly apply water onto or into the unit.

Door Alignment (see fig. # 1)

1. Remove the top hinge cover.
2. Loosen the top hinge screws using a Phillips Head Screwdriver.
3. Adjust the door.
4. Replace the top hinge cover.
5. Adjust bottom hinge if necessary.

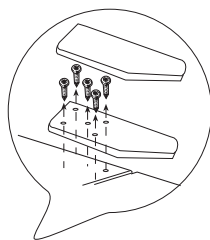
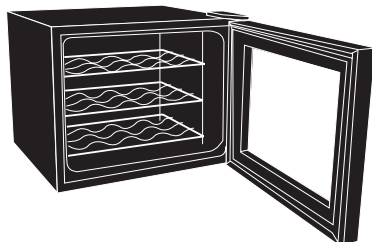
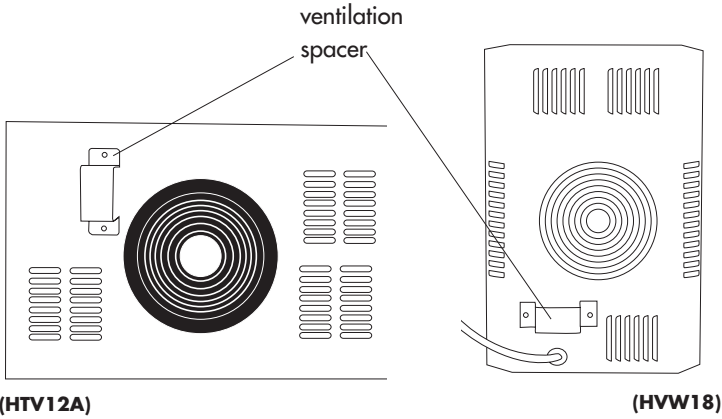

fig. # 1



Installing Spacer

To ensure good ventilation, **YOU MUST** install the provided ventilation spacer as shown on the rear of the unit.



(HTV12A)

(HVW18)

Wine Cellar Features & Use

General Features

Temperature Adjustments:

- Your wine cellar has a temperature control knob on the back of the unit. There are 2 settings: 1 for the red wine and the other for white wines. You can set the temperature of your wine cellar at any setting you desire.



(HTV12A)

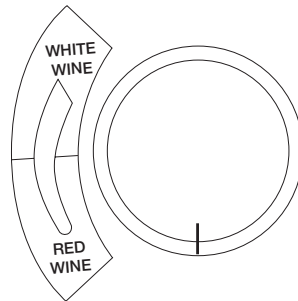

(HVW18)

NOTE: White wine temperature is cooler than red wine temperature.

Proper Wine Cellar Care and Cleaning

Cleaning and Maintenance

Warning: To avoid electric shock always unplug your wine cellar before cleaning. Ignoring this warning may result in death or injury.

Caution: Before using cleaning products, always read and follow manufacturer's instructions and warnings to avoid personal injury or product damage.

General:

- Prepare a cleaning solution of 3-4 tablespoons of baking soda mixed with warm water. Use sponge or soft cloth, dampened with the cleaning solution, to wipe down your wine cellar.
- Rinse with clean warm water and dry with a soft cloth.
- Do not use harsh chemicals, abrasives, ammonia, chlorine bleach, concentrated detergents, solvents or metal scouring pads. SOME of these chemicals may dissolve, damage and/or discolor your wine cellar.

Power Interruptions

- Occasionally there may be power interruptions due to thunderstorms or other causes. Remove the power cord from AC outlet when a power outage occurs. When power has been restored, replugin power cord to AC outlet.

Vacation and Moving Care

- For long vacations or absences, unplug the unit, empty contents from wine cellar, and clean the wine cellar and door gaskets according to "General cleaning" section. Prop doors open, so air can circulate inside. When moving always move the entertainment center vertically. Do not move with the unit lying down.

Troubleshooting

Wine Cellar does not operate

- Check if wine cellar is plugged in.
- Check if there is power at the ac outlet, by checking the circuit breaker.

Wine appears too warm

- Frequent door openings.
- Allow time for recently added wine to reach desired temperature.
- Check gaskets for proper seal.
- Adjust temperature control to colder setting.

Wine temperature is too cold

- If temperature control setting is too cold, adjust to a warmer setting.

Wine cellar runs too frequently

- This is normal to maintain temperature.

Moisture build up on interior or exterior of the wine cellar:

- This is normal during high humidity periods.
- Prolonged or frequent door openings.
- Check door gaskets for proper seal.

Wine Cellar door does not shut properly:

- Level the wine cooler.
- Check for blockages e.g. wine bottles, shelves.

Limited Warranty

What is covered and for how long?

This warranty covers all defects in workmanship or materials for a period of:

12 months labor (carry-in)

12 months parts

The warranty commences on the date the item was purchased and the original purchase receipt must be presented to the authorized service center before warranty repairs are rendered.

EXCEPTIONS: Commercial or Rental Use warranty

90 days labor (carry-in only)

90 days parts

No other warranty applies

What is covered.

1. The mechanical and electrical parts, which serve as a functional, purpose of this appliance for a period of 12 months. This includes all parts except finish, and trim.

What will be done?

1. We will repair or replace, at our discretion any mechanical or electrical part which proves to be defective in normal usage during the warranty period so specified.
2. There will be no charge to the purchaser for parts and labor on any covered items during the initial 12 month period. Beyond this period only parts are covered in the remaining warranty. Labor is not provided and must be paid by the customer.
3. Contact your nearest authorized service center. For the name of the nearest service center please call 1-877-337-3639

THIS WARRANTY COVERS APPLIANCES WITHIN THE CONTINENTAL UNITED STATES, PUERTO RICO AND CANADA. IT DOES NOT COVER THE FOLLOWING:

Damages from improper installation.

Damages in shipping.

Defects other than manufacturing.

Damage from misuse, abuse, accident, alteration, lack of proper care and maintenance or incorrect current or voltage.

Damage from other than household use.

Damage from service by other than an authorized dealer or service center.

Decorative trims or replaceable light bulbs.

Transportation and shipping.

Labor (after the initial 12 months).

THIS LIMITED WARRANTY IS GIVEN IN LIEU OF ALL OTHER WARRANTIES, EXPRESSED OR, INCLUDING THE WARRANTIES OF MERCHANTABILITY AND FITNESS FOR A PARTICULAR PURPOSE

The remedy provided in this warranty is exclusive and is granted in lieu of all other remedies.

This warranty does not cover incidental or consequential damages, so the above limitations may not apply to you. Some States do not allow limitations on how long an implied warranty lasts, so the above limitations may not apply to you.

This warranty gives you specific legal rights, and you may have other rights, which vary, from state to state.

Haier America
New York, NY 10018

IMPORTANT

Do Not Return This Product To The Store

If you have a problem with this product, please contact
the "Haier Customer Satisfaction Center" at 877.337.3639.
DATED PROOF OF PURCHASE REQUIRED FOR WARRANTY SERVICE

IMPORTANT

Ne pas Réexpédier ce Produit au Magasin

Pour tout problème concernant ce produit, veuillez contacter le service des consommateurs
"Haier Customer Satisfaction Center" au 1-877-337-3639.
UNE PREUVE D'ACHAT DATEE EST REQUISE POUR BENEFICIER DE LA GARANTIE.

IMPORTANTE

No regrese este producto a la tienda

Si tiene algún problema con este producto, por favor contacte
el "Centro de Servicio al Consumidor de Haier" al 1-877-337-3639 (Válido solo en E.U.A).
NECESITA UNA PRUEBA DE COMPRA FECHADA PARA EL SERVICIO DE LA GARANTIA

Haier[®]

Made in China
Fabriqué en Chine
Hecho en China

Haier America
New York, NY 10018

Printed in China